

# STRAIGHTLINE PERFORMANCE

## Polaris RZR Reverse Light Kit

### Installation Manual 287-113

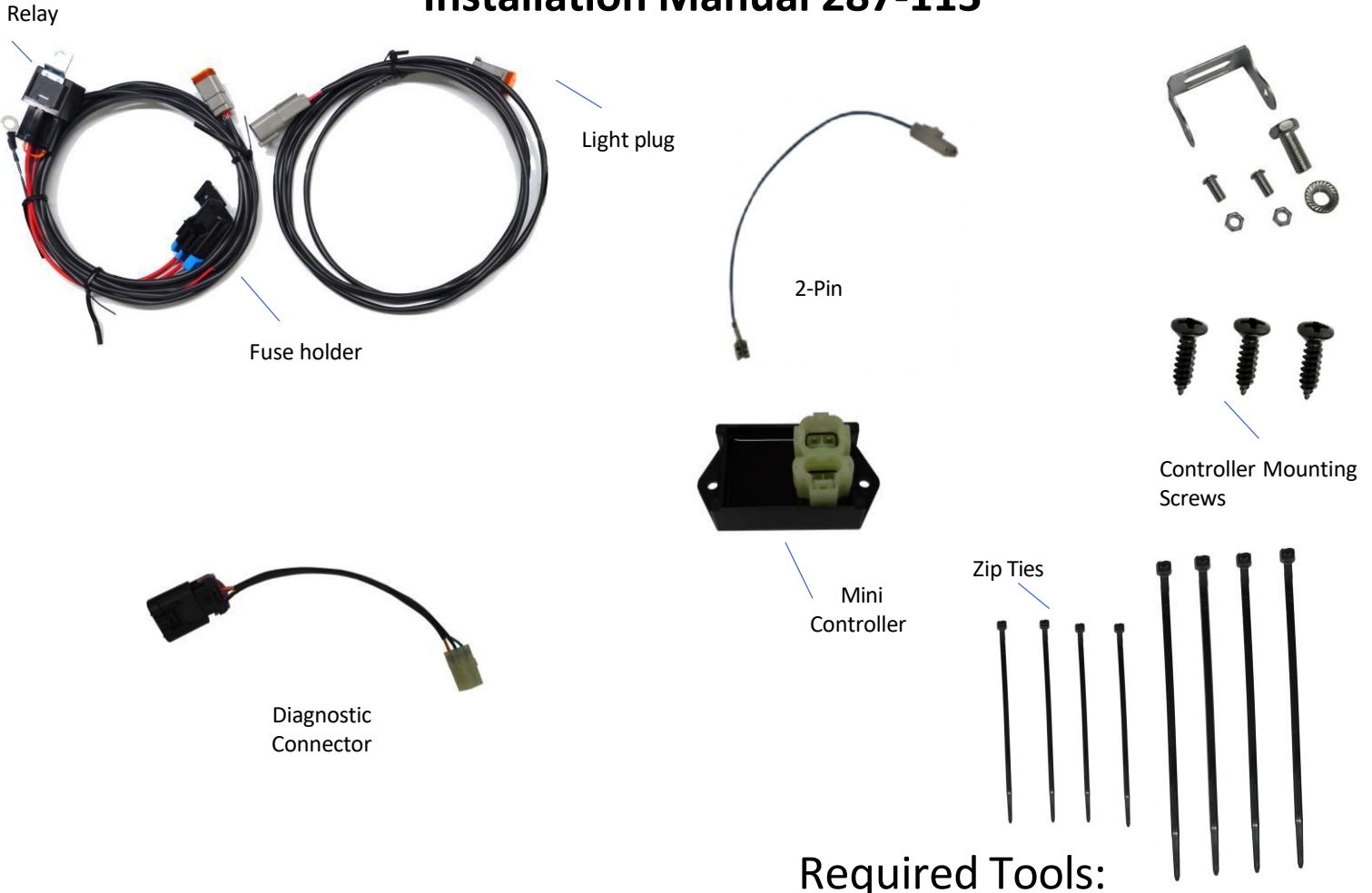

### Required Tools:

Torx T-30
5/16" Allen Wrench
Philips Screwdriver
Utility Knife
3/8" Socket

Read entire manual before beginning the installation process.

Disclaimer: Straightline Performance is not responsible for any damage due to improper installation.

# Step 1: Remove Seats & Plastics

- 1) Remove hood (twist the two quarter-turn locks.)
- 2) Remove seats by pulling up on the release at the rear of the seat.
- 3) Remove center console by removing the four push-rivets and the three T-30 screws.
- 4) Remove plastic cover in box.



## Step 2: Secure & Plug in Controller

- 1) Remove the diagnostic connector cover, plug in connector that comes with reverse light wiring harness.
- 2) Secure controller, relay, and fuse using provided screws.
- 3) Remove nuts with 3/8" socket.
- 4) Secure the red ring to positive terminal and the black ring to negative terminal.

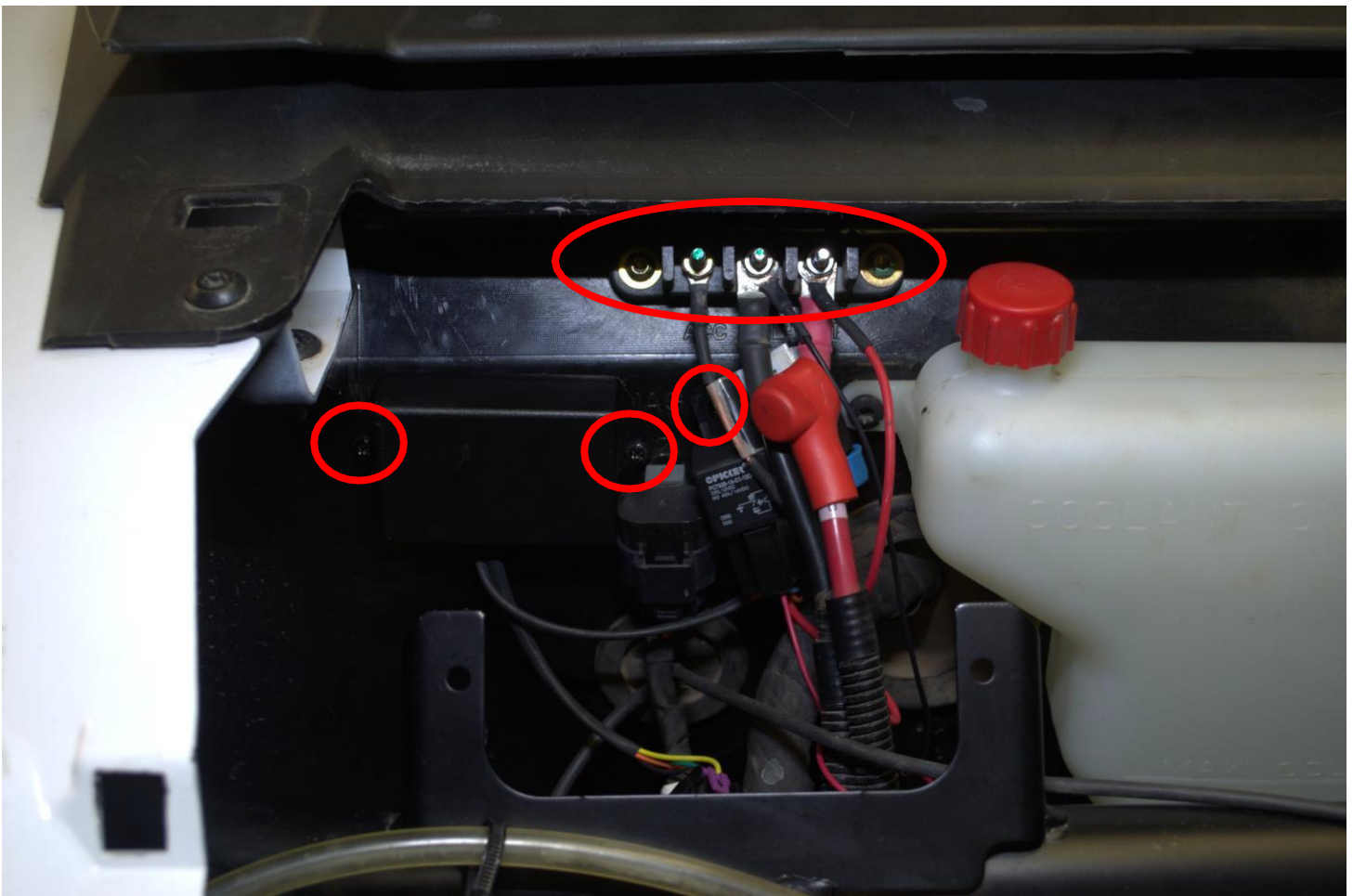

## Step 3a: Mounting the Light

This step is for a one-piece light kit. Refer to Step 3b for two-piece light kit.

- 1) Remove the taillight housing by removing five T-30 screws.
- 2) Drill a 5/16" hole.
- 3) Attach the light to its bracket.
- 4) Feed the light connector through the center hole in the taillight housing.
- 5) Slide the bolt through the newly-drilled hole and tighten the bolt.



## Step 3b: Mounting the Light

This step is for a two-piece light kit.

- 1) Mount the two included bar clamps to each side of the roll cage, using a 5/32" allen wrench to tighten the bolts.
- 2) Attach lights to their brackets. Be sure to slide the bolt through the bracket before attaching to the light. Use 5/32" allen wrench to tighten allen bolts.
- 3) Bolt lights to the bar clamps. Tighten bolts with 1/2" wrench.



## Step 4a: Route Power to Light

This step is for a one-piece light kit. Refer to Step 4b for a two-piece light kit.

- 1) Route reverse light harness down from the control box position into the cab, and, following the OEM harness, run straight through cab, then run up to plastic cover in box.
- 2) From there, route the wiring harness back to the reverse light connector.
- 3) Plug wiring harness connector into light connector.
- 4) Zip tie as needed.

**Note: If installing kit on 2-seater, coil excess wire either by control box or directly behind seat.**



## Step 4b: Route Power to Light

**This step is for a two-piece light kit.**

- 1) Route reverse light harness down from the control box position into the cab, and, following the OEM harness, run straight through cab.
- 2) When directly behind seats, run harness up to roll bar.
- 3) Plug short-wired connector into light on closest side.
- 4) Run longer wire to other side of cab, then plug connector into the other light connector.
- 5) Zip tie as needed.

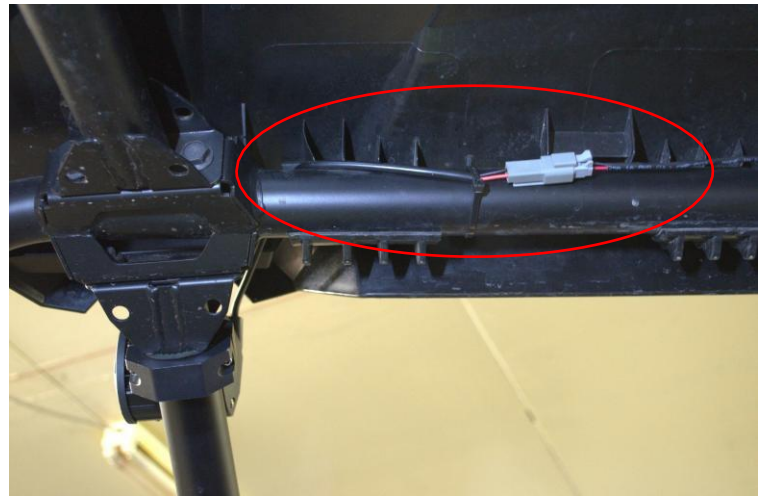

# Step 5: Reinstall Plastics



## Automatic Reverse Light

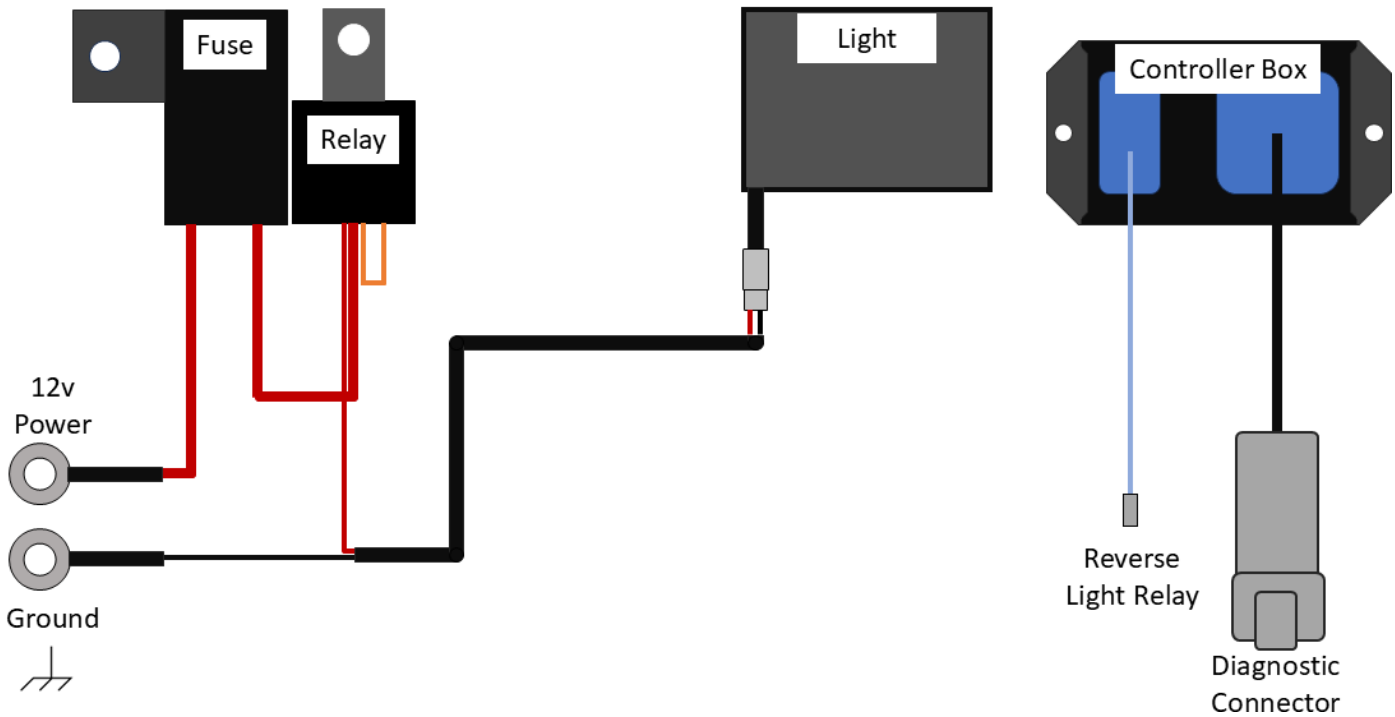



## Operation of Reverse Lights

Our controllers have been programmed with a manual override feature. Backup lights may be turned on without the vehicle in reverse.

- **Fully Automatic when shifted to Reverse Gear**

- 1) No programming required

- **Manual Override Function**

- 1) Shift the vehicle into Neutral
- 2) Press and hold the brake pedal for up to 2 seconds. The reverse light will automatically turn on and stay on.

**\*To turn the light off repeat this procedure.**

**Note:** If the ignition is turned off while the vehicle is in reverse, or the manual override function is enabled the lights will remain ON until the ECU enters sleep mode (approximately 30 secs to 2 minutes depending on vehicle and ECU type).

Part Number	Description	Qty	
IT-238-102	3 screws in baggie	1	
IT-287-100	60" wire harness, single connector for light, battery terminals, includes relay	1	
IT-287-102	Polaris Diagnostics Adapter Purple and black 8 pin plug on one end and 4 pin white plug on the other.	1	
IT-287-105	Polaris controller	1	
IT-287-110	Blue 4" jumper from harness relay to controller, 2 pin plug on one end flat locking spade on other.	1	
IT-288-102	1 Zip tie with push insert holder	4	
Np-209	zip ties 6"	10	
	Make sure Light has bracket (SPI in house)		
	Pin blue wire into relay housing, directions in folder (SPI in house)		
Sticker	2 stickers	1	
Directions	bom	1	