

STRAIGHTLINE PERFORMANCE

CAN-AM Defender Reverse Light Control Kit Installation Manual 282-107



Required Tools:

10mm Socket & Ratchet
10mm Wrench
13mm Socket & Ratchet
13mm Wrench
Philips Screwdriver
5/16" Drill Bit
Flat Head Screwdriver
Wire Cutter (trimming zip ties)

Read entire manual before beginning the installation process.

Disclaimer: This is an aftermarket product being installed out of our control. By installing this product, you are assuming liability for any damage that may occur. If you are not comfortable with the install process, please contact your vehicle dealer for assistance. Straightline performance is not liable for any damage.

Step 1: Secure and Plug-in Controller

- 1) Remove diagnostic connector and plug connector into controller.
- 2) Secure controller with provided mounting screws; if necessary, drill 1/16" pilot hole.

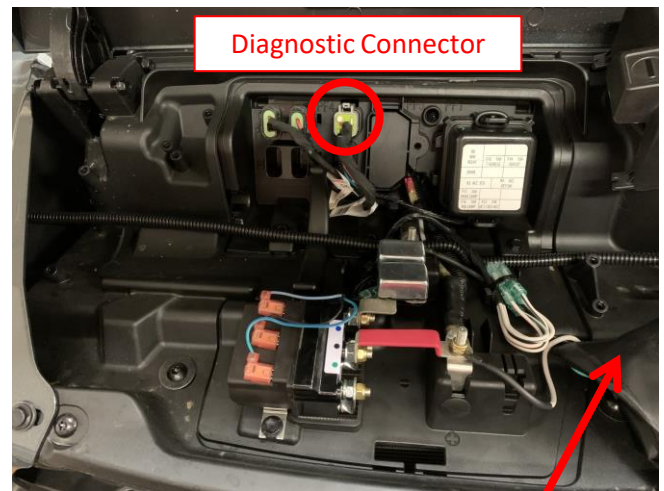
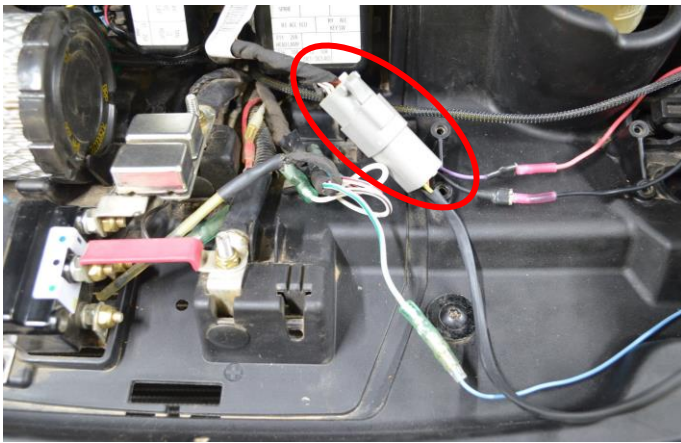

Mount Controller In
This Area

Step 2: Control Wire Install

- 1) Some vehicles are pre-wired from the factory. This would look like the top pictures below
- 2) If your vehicle does not have the factory wiring, proceed to step 2b.
- 3) If your vehicle has these wires, connect the Straightline kit blue wire to the factory solid white wire under the hood per the bottom picture

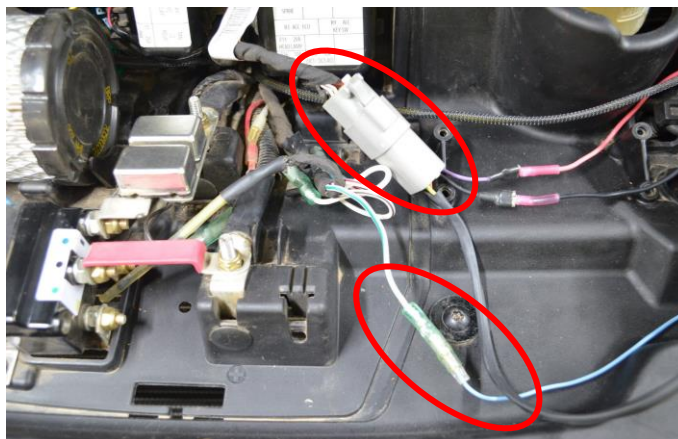
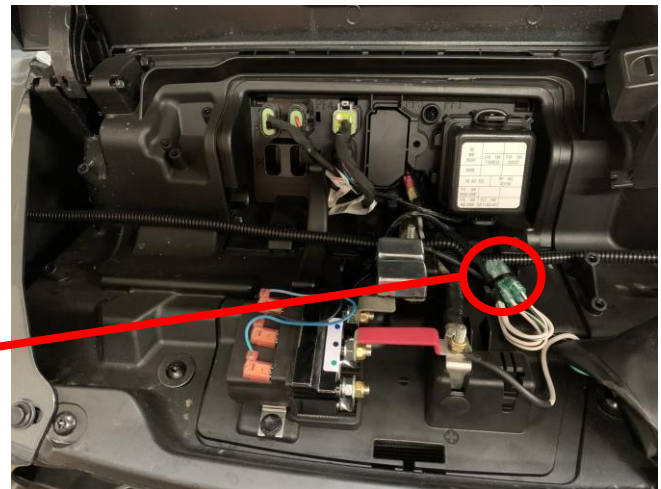

Diagnostic and control wire connected.

Step 2: Routing Wires Under Dash & Floor

- 1) Under the center of the dash behind the switch block, 4 factory wires will be visible.
- 2) Connect the solid white wire to the solid blue wire using the 4" jumper.
- 3) Remove the center floor board tunnel cover.
- 4) Connect the Light Blue wire coming out of the Straightline kit relay to the factory Solid Blue wire back by the battery. For the longer vehicles (MAX or 4 passenger) connect the extra 60" wire to the solid blue factory wire and connect to the blue wire coming out of the relay. Pictures below and schematic on the next page. If the 60" extension was not used, it can be discarded.

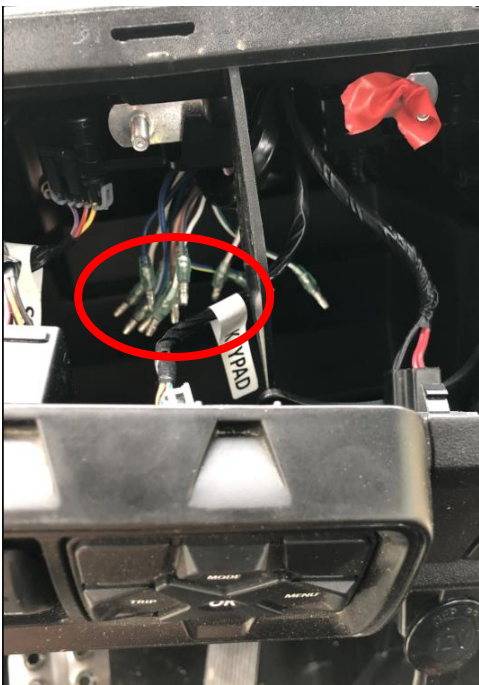

Factory wiring in dash. Jump the white and solid blue wires with the 4" jumper.

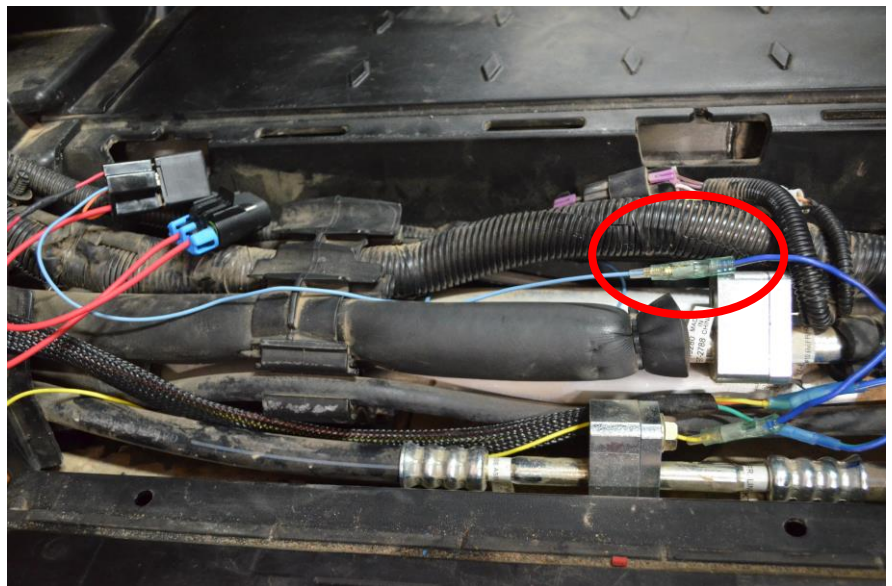

Factory wiring in floor board tunnel. Connect solid blue factory wire to blue Straightline wire. The 60" extension may be needed.

Step 2: Routing Wires Under Dash & Floor

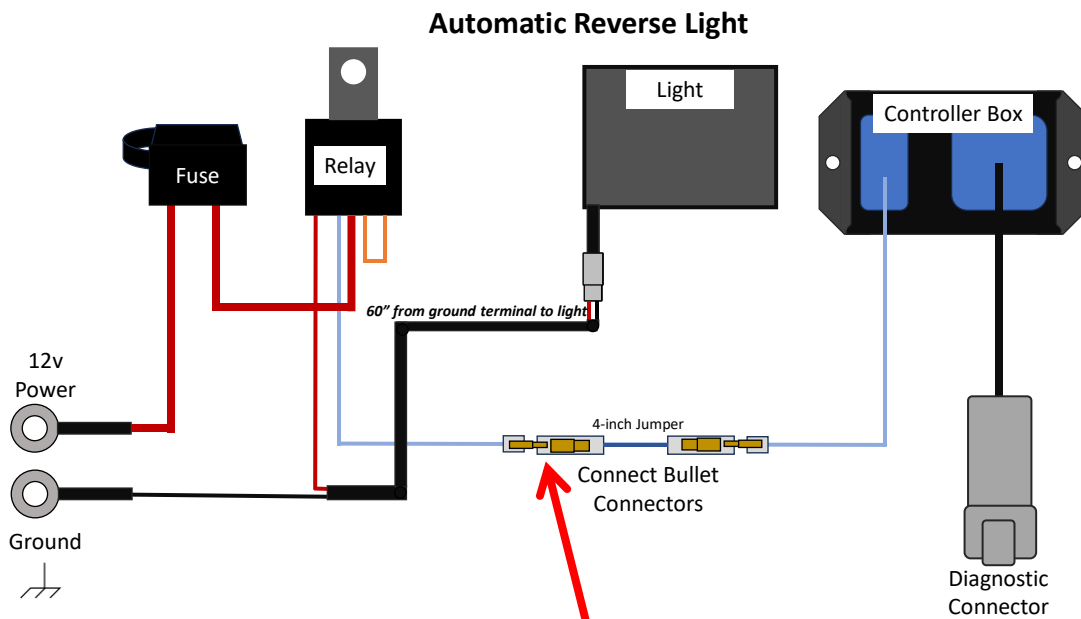

Solid blue factory wiring connects here.

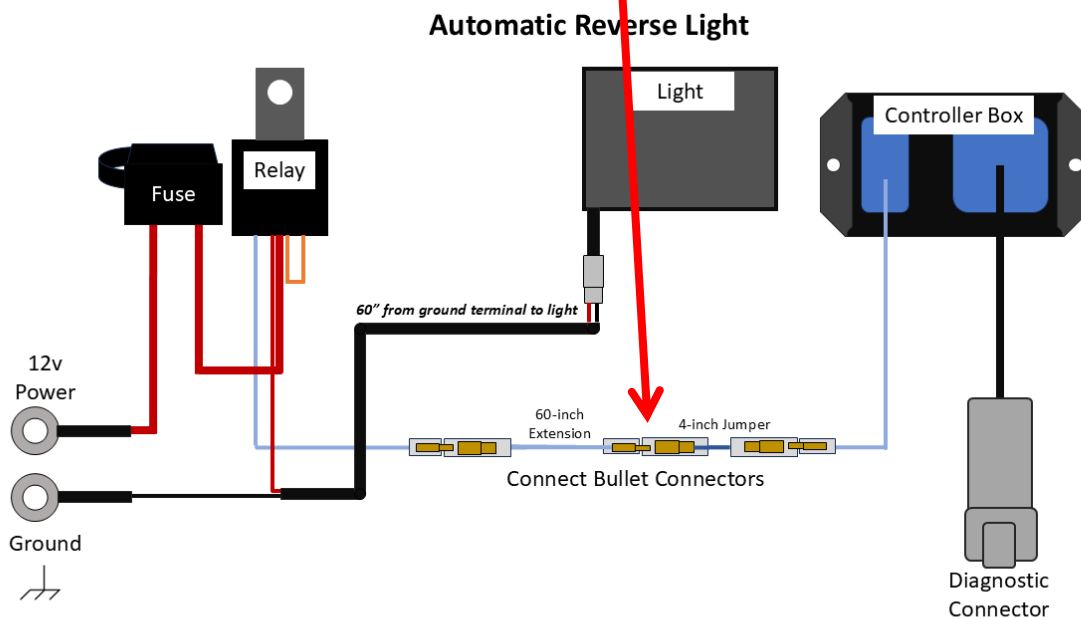

Step 2b: Routing Wires Under Dash & Floor

- 1) For vehicles without the factory pre-wiring.
- 2) For regular 2 passenger vehicles, plug the 120" extension wire provided in the kit into the Light Blue wire from the Straightline controller.
- 3) Route the jumper wire through the firewall. Remove the winch-control outlet to gain access - there is a rubber seal that runs across the frame, sealing the cab.
- 4) Route the wire into the cab area in a way that it doesn't get pinched or rub any sharp edges.
- 5) Remove the center floorboard cover and route the wire back to the battery area. Connect the jumper wire to the Light Blue wire coming out of the relay on the Straightline wire harness. Use the 60" wire if needed to get to the battery.
- 6) Secure the wire so that it is away from any rotating components or pinch points.



Step 2b: Routing Wires Under Dash & Floor

Automatic Reverse Light

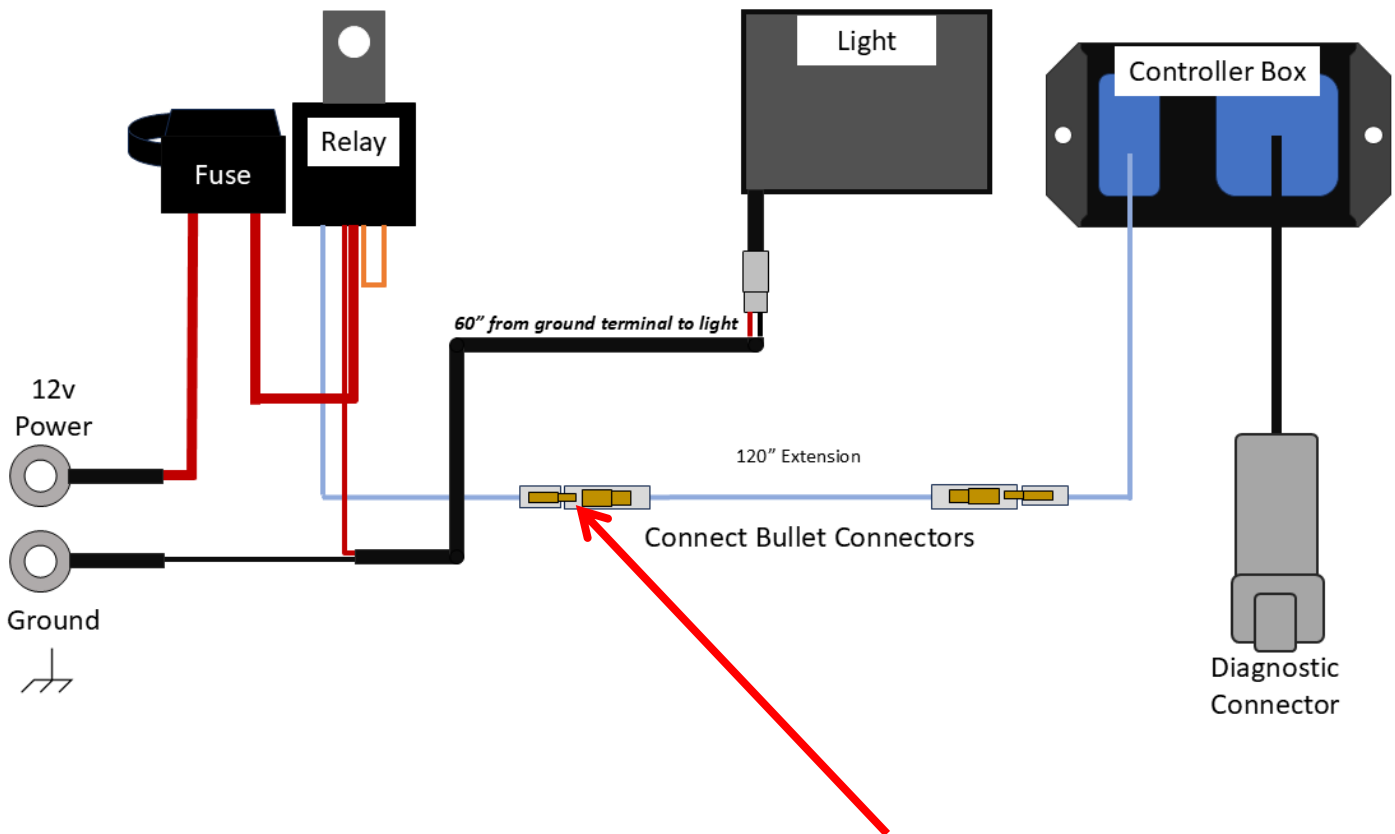

Long vehicles may require adding in the 60" extension here.

Step 4: Route Harness & Attach Leads

- 1) Route provided wiring harness to battery compartment.
- 2) Keep harness away from hot or rotating parts at all times. Zip tie as needed.
- 3) Attach black ring terminal to negative battery terminal.
- 4) Attach red ring terminal to positive battery terminal.
- 5) Secure fuse and relay using zip ties.
- 6) Route lighting connection to your lighting location. Use supplied connectors to update your light wiring to mate with the kit. System will work with 1 or 2 lights connected.
- 7) If you purchased our accessory lights, see that instruction manual for tips on routing the wire to work with those lights.
- 8) Note, you may have extra blue extension wires depending on the model vehicle that you have that can be discarded.

General Reverse Light Wiring

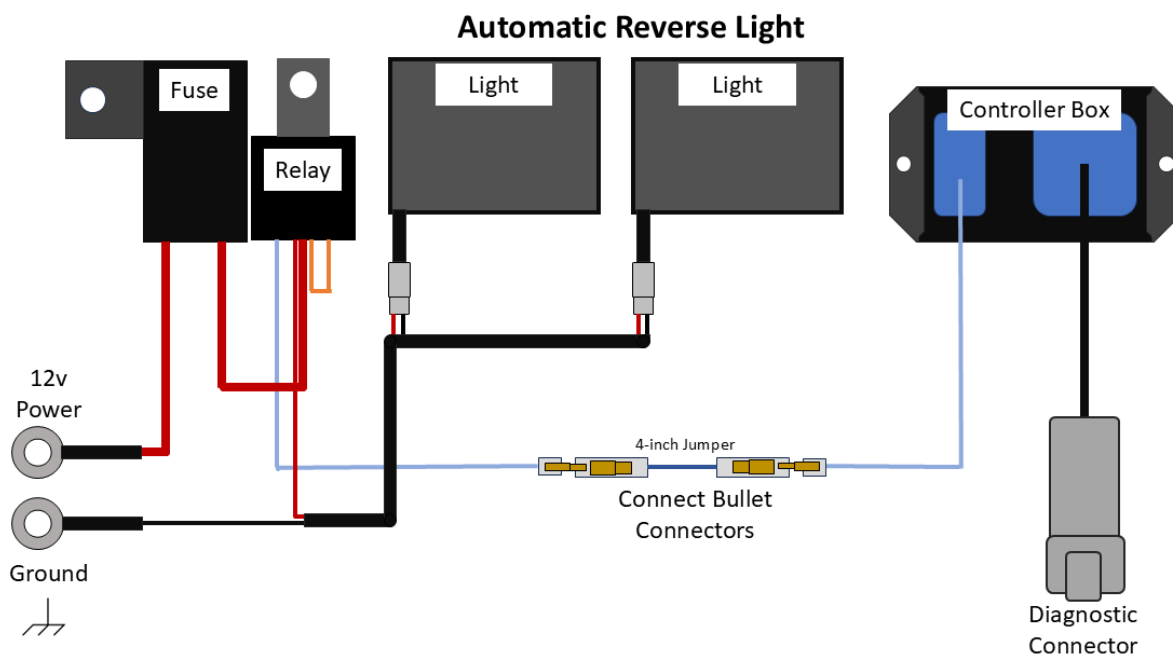

Step 1: Mounting the LED Lights

- 1) Remove one T-40 bolt on upper door hinge. Install supplied bracket reinstall bolt; then, remove second bolt, slide bracket in place and reinstall bolt. Repeat on the other side.
- 2) Remove the headliner and anything else preventing access to the rear of the cab.
- 3) Carefully drill a 5/16" hole
- 4) Feed the wires into the cab.

Note: If installing on an enclosed cab, use included rubber grommets in the new hole.



Step 2: Assemble Connector

- 1) Assemble the connector onto the light harness by pushing the red wire into the hole marked 1 and the black into hole 2. Push the wires in until they click into place and lock into the connector. Give the wires a light tug to make sure they are seated.
- 2) Push the green wedge lock in until it clicks.
- 3) Connect the lights to the harness supplied with the base kit. Make sure the long part of the wiring is on the passenger side.



Note: Holes are numbered on the side, near the point where the connector becomes wider

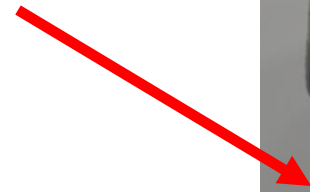

Step 3: Route LED Light Harness

- 1) These steps are only needed if you have not already installed the lighting wiring.
- 2) For a cleaner install, remove the single red long wire from the relay connector. This is done by removing the relay and pressing the metal connector tab down with a small flat blade screw driver and lightly pulling on the wire.
- 3) If the tab is laying flat, carefully bend it back out so that it will lock when reinstalling.

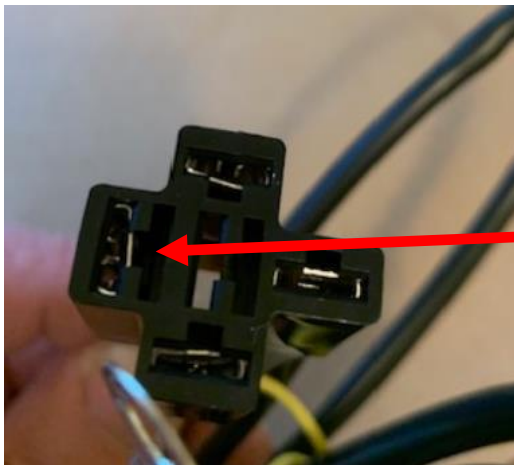

Insert flat blade screw driver here, pressing down on the connector tab and lightly pulling on the wire.

Bend tab out if laying flat.

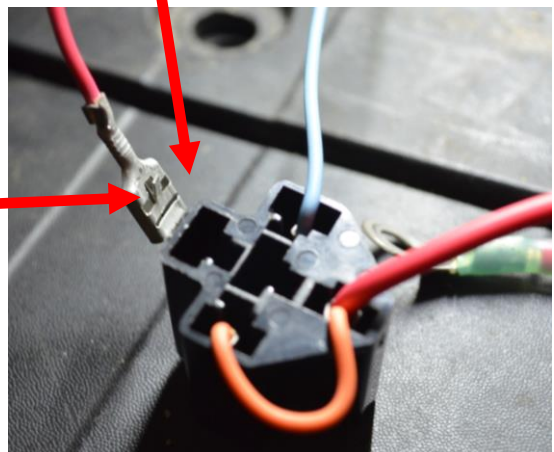

Step 3: Route LED Light Harness

- 1) Remove the plastic cover near the lower door hinge.
- 2) If you have removed the red wire from the relay connector, run wires (ring terminal and relay terminal end) from inside the cab down the inside of rear passenger pillar; retrieve wires from the hole right below the lower door hinge. If you have not removed the red wire, run the wire down the outside of the frame tube and secure.
- 3) Route wire up to the battery and reinstall plastic cover.

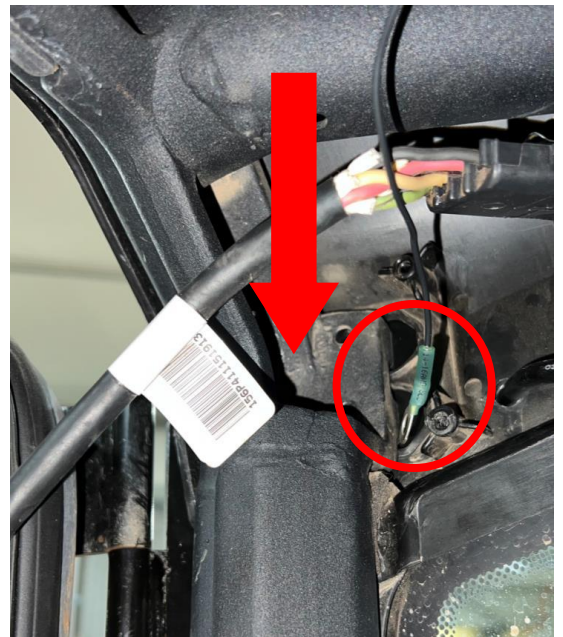

Step 4: Attach Power Leads and Relay

- 1) Attach black ring terminal to negative battery terminal.
- 2) If the red wire was removed, reinstall the wire back into the relay housing; push in until it clicks. Give it a slight tug to make sure it is secure. Reinstall the relay into housing. Attach red ring terminal to positive battery terminal.
- 3) Secure fuse and relay using zip ties.
- 4) Reinstall headliner and anything else that was removed.

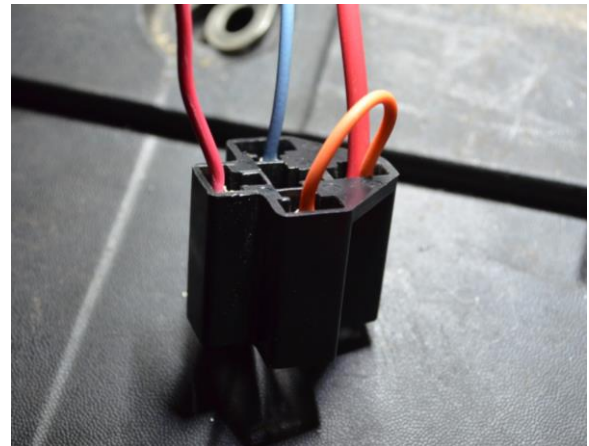
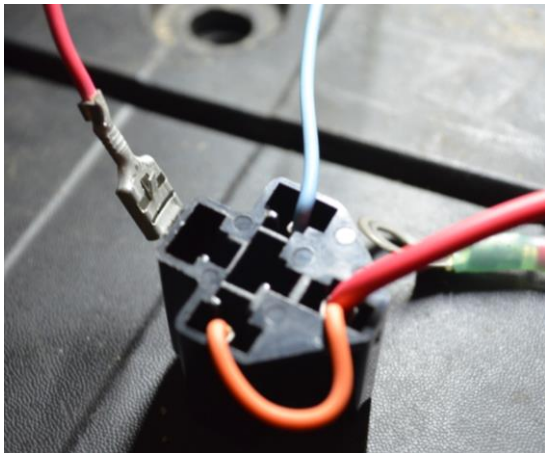

Automatic Reverse Light Wiring

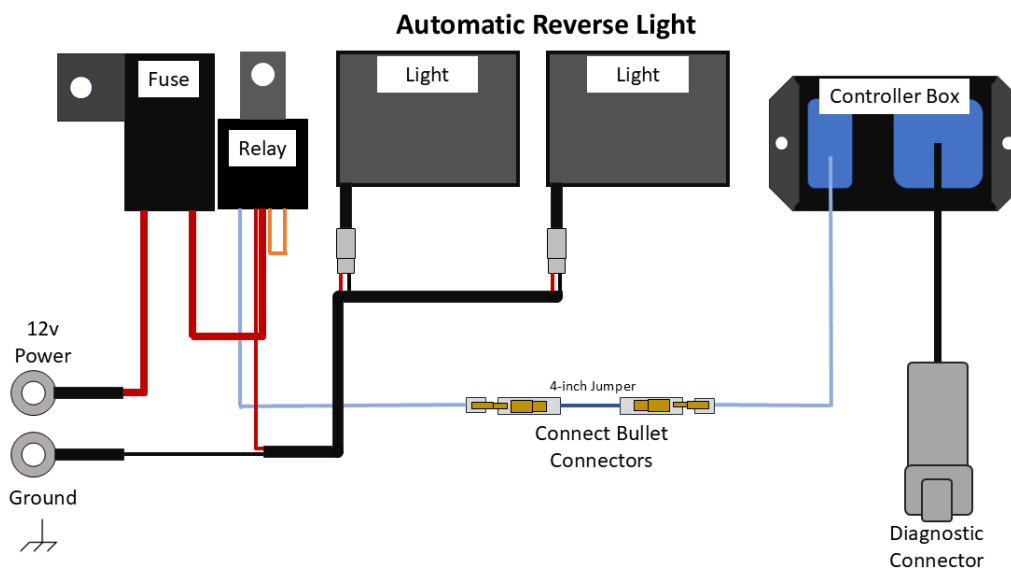



Operation of Reverse Lights

Straightline Backup Lights are automatic. **NO switches or programming required.** When the vehicle is shifted into reverse, the lights will automatically come on. The controller has been programmed with a manual override feature, so back-up lights can be turned on without the vehicle needing to be shifted into reverse.

- Fully Automatic When Shifted to Reverse

- 1) No programming needed

- Manual Override Function

- 1) Shift the vehicle into Neutral
- 2) Press and hold the brake pedal for up to 2 seconds. The reverse light will automatically turn on and stay on.

***To turn the light off repeat this procedure.**

Note: If the ignition is turned off while the vehicle is in reverse, or the manual override function is enabled, the lights will remain ON until the ECU enters sleep mode (approximately 30 secs to 2 minutes depending on vehicle and ECU type).

Part Number	Description	Quantity	In Box
IT-232-100	Defender light bracket	2	
IT-238-102	3 screws in baggie	1	
IT-282-100	8" blue Backup controller wire, 2 pin plug one end male bullet other end.	1	
IT-282-106	Blue 30" extension with relay connector on one end and male bullet on other end	1	
IT-282-111	Canam defender CAN control box	1	
IT-282-113	CanAm Diagnostics adapter. 6 pin Deutsch plug one end 4 pin plug on the other.	1	
IT-282-114	Blue 120" with female connectors on both ends	1	
IT-282-115	Wiring harness with dual light plugs and battery terminals	1	
IT-282-116	4" Blue adapter, female bullet connectors on each end.	1	
IT-282-117	Blue 60" with female connector on one end, male on the other end.	1	
IT-288-110	Cube shape light with pins with Bagged female Deutsch connector with seal and lock.	2	
	Make sure lights has bracket for mounting		
IT-288-106	Rubber gromet	2	
NP-209	zip tie 6"	10	
	Pin in blue wire to relay, directions in folder (SPI in house)		
Sticker		2	
Instruction	Instructions	1	