

# STRAIGHTLINE PERFORMANCE

**Skidoo 600 EFI NEO High Elevation Clutch Kit 6000ft+ with SPI pipe (121-265)**

**Be sure to check out the single pipe for more MPH!**

### Parts included in Clutch Kit:

- 1 - Primary Spring: White (121-255)
- 1 - P-Drive Adjustable Weight Kit (121-235)
- 1 - Secondary QRS Spring: Silver (121-157)
- 1 - Helix-SPI-27 QRS Helix
- 1 - Complete Set of Straightline Clickers (121-236)

### P-Drive Weight Settings:

Operating RPM 6800-7000 RPM

### Straightline Exhaust Settings

12.8 Pivot Bolt + 1 washers

Hole #1 - 0

Hole #2 - 0

Clicker Position #3

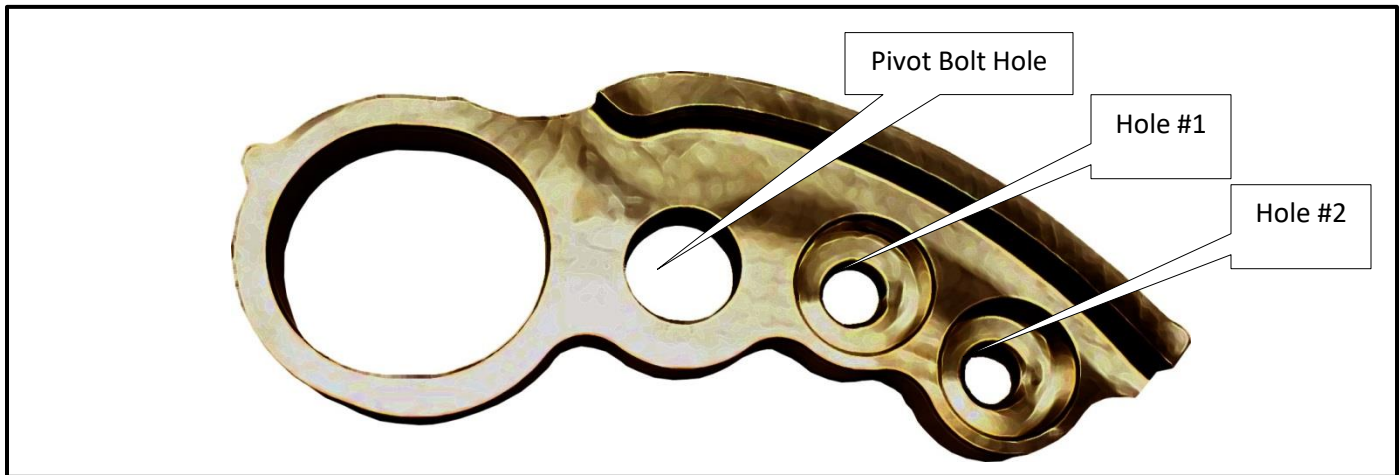

## Primary Clutch Installation

1. Step one is to install the proper weight into the each hole. Settings are in upper right hand corner of this page. The proper weight set-up is with a bolt and washer combinations that install into each location. Diagram #1 shows what hole locations are dictated by the numbers. (please note these are base settings, and for fine tuning, please refer to the tuning information on the 4th page.
2. Next, remove the P-drive using the proper puller and holders (Straightline part #151-113 & 151-114) this will allow for the installation of the new weights and primary spring.
3. After the P-drive is removed, you will need to leave the puller installed and hit the end of the puller to separate the sliding and fixed sheaves. After the sliding and movable sheave are separate, you can remove the damper. #2 & #3
4. Next, installation of the primary spring can be done, install the Straightline tools, (151-111 & 151-112) into the primary clutch as shown on the next page, to install the new spring. When compressed remove the C-clip to remove the spring cup. #4 & #5 & #6
5. While the Spring is out, installation of the new clutch weights can be done, as this will help speed up the installation.
6. After installation of the clutch weights, re-installation of the primary spring can be done. Simply compress the spring cup back down and install the C-clip.

7. Next, install the damper and torque at 23ft lbs as shown, on picture #7
8. After complete installation be sure that all the clicker positions match the setting in the upper right hand corner. You can simply loosen the "pivot" bolt and turn the clicker while the clutch weight is installed. #8

**A Straightline Clutch kit should always be installed by a certified snowmobile professional. Improper setting or installation can cause the machine to perform incorrectly or engine damage.**

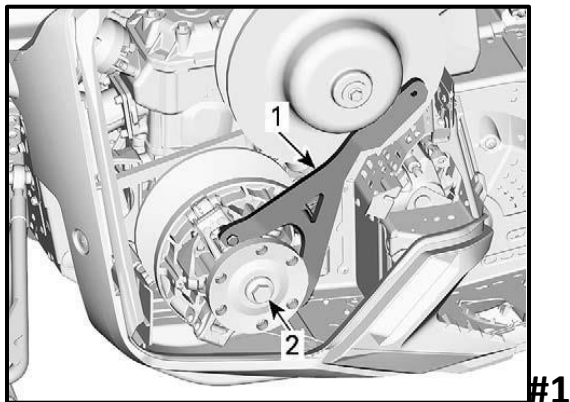

#1

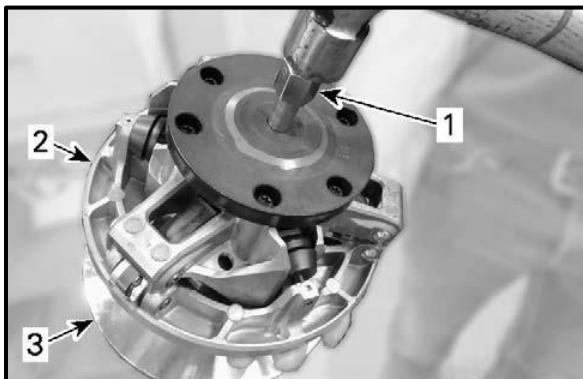

#2

1. Puller
2. Sliding Sheave
3. Fixed Sheave

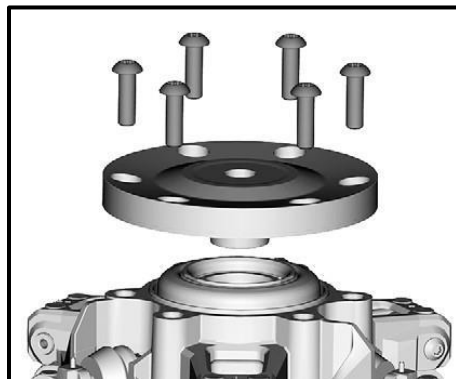

#3

Remove the Damper

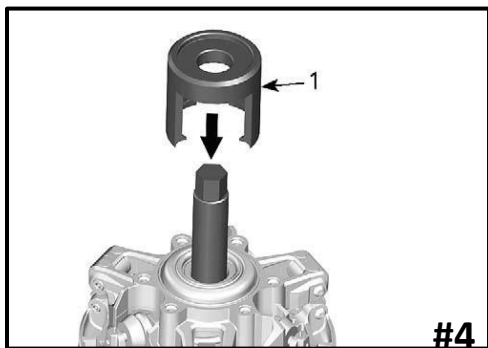

#4

Install Puller Stud

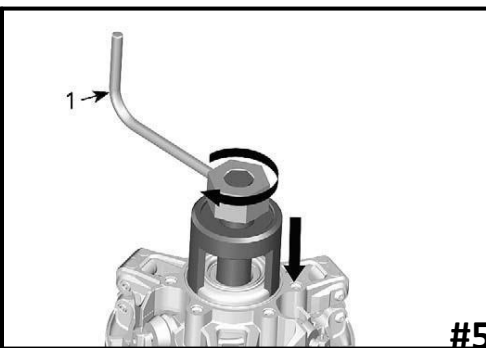

#5

Compress Spring Cup

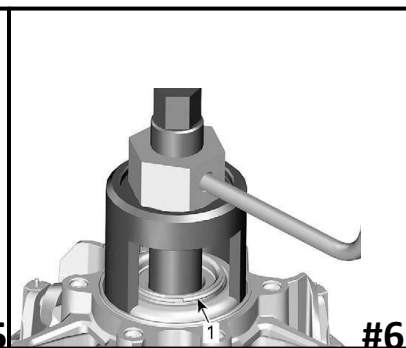

#6

Remove Circlip #1

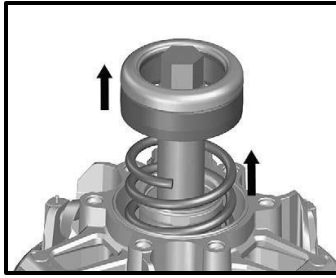

Remove spring cup, install spring after installation of clutch weights

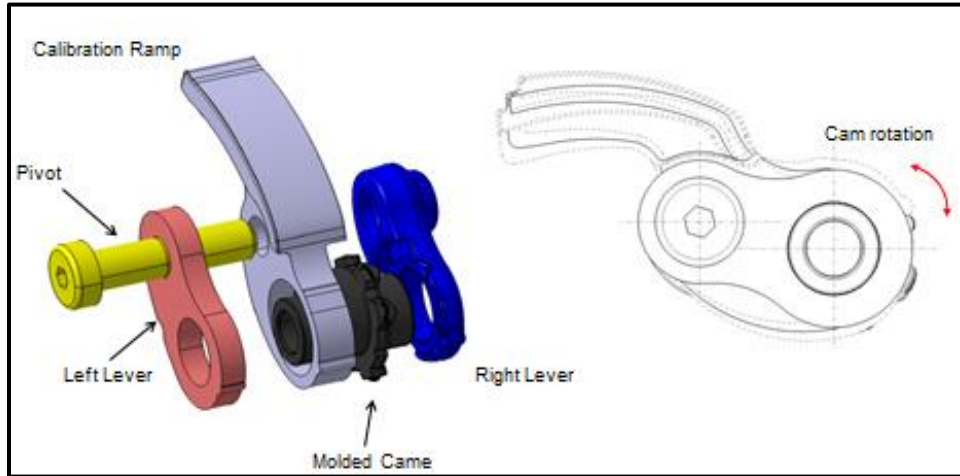

Remove all Skidoo P-drive side components and install new Straightline clutch weights.

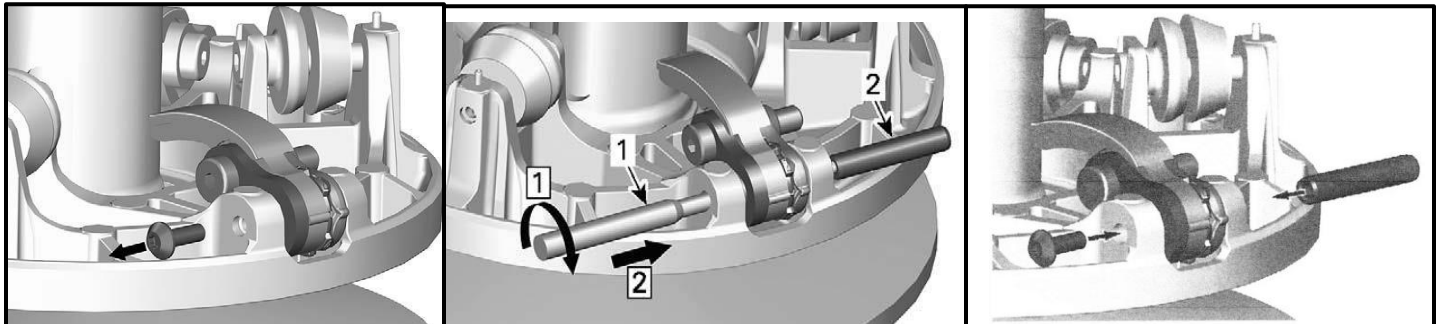

Unscrew the Bolt that holds the clutch weight in, then install the tool to remove the pin as it is pressed in. This will require some slight tapping to remove. After the clutch weight is removed you can install the stock Skidoo components onto the Straightline clutch weight. The Explode view above will show proper assembly.

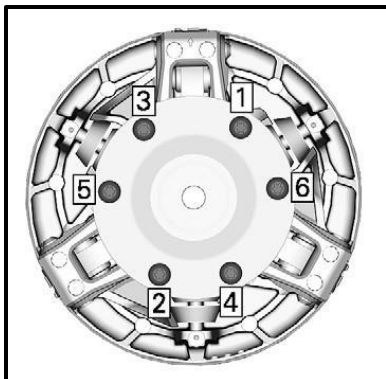

Torque sequence for Damper

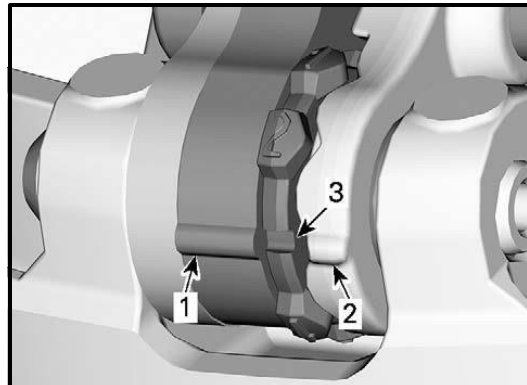

#7

#8

- #1 Clutch weigh
- #2 Side Plate
- #3 Clicker Number

# Secondary Clutch Installation

## Proper Installation using the Straightline QRS Helix Compressor (151-107)

- Step 1. Remove the stock belt adjuster from the outer shaft of the QRS clutch.
- Step 2. Insert tool inside of the hollow shaft of the QRS clutch, and tighten the nut down against the spacer. This can be done by hand. When the nut is too tight to turn by hand, use a wrench on the nut for extra support. It will not take a lot of pressure to support the tool.
- Step 3. Install the plastic tube, then the washer, and last the handle. Turn and compress. It will only need to compress a 1/2" to aid remove the bolts. Lastly, unwind.

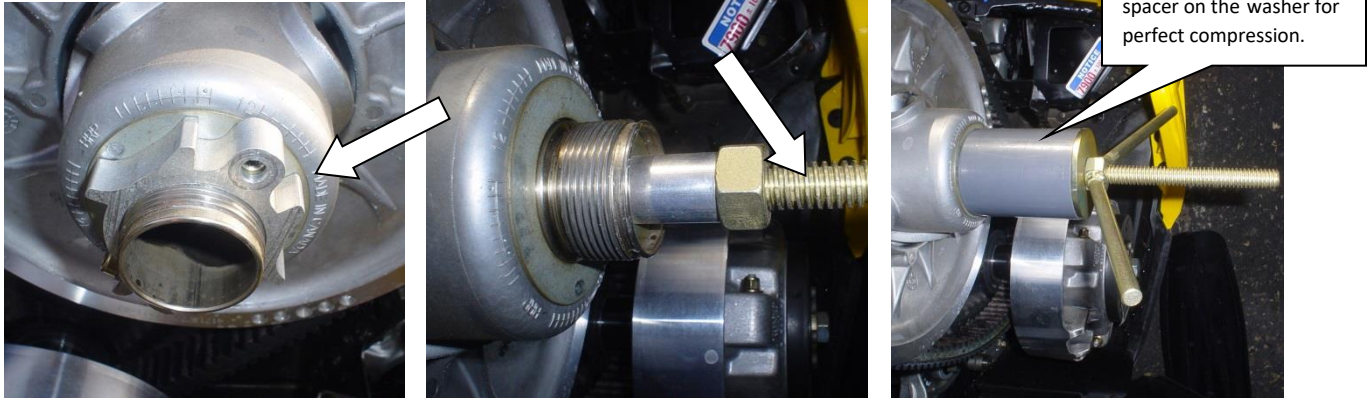

### BOM:

Quantity	Part #	Descriptions	In Box
1	121-235	P-Drive Weight Set	
1	121-255	P-drive Primary Spring	
1	121-157	Secondary Spring	
1	121-236	P-Drive Clicker Kit	
1	SPI-27	Straightline Custom QRS Helix	
1		Sticker	

Checked and Packaged By

Straightline Performance 651-466-0212 [www.straightlineperformance.com](http://www.straightlineperformance.com)

Technical questions please email [tech@straightlineperformance.com](mailto:tech@straightlineperformance.com)



Facebook @ straightlineperformanceinc1  
 Youtube @ straightlineperfin  
 Twitter @ straightlineperf